

# Plasma/LCD Stands

## Commercial Series

### Mobile Display Floor Stand – Economy



SPEC SHEET

#### Features

The 8FSLU 343 is a versatile stand that allows large plasma displays to be moved from room to room with ease and safety. Unique base design allows movement through standard doorways. 100 mm castors.

Optional shelf for related equipment. Adjustable height and reversible -face forward or away from audience. Deep satin silver finish. Code 8FSLU SHELF.

**Made by Gilkon in Australia.**



Screen not included

MOBILE PLASMA DISPLAY STAND ECONOMY	
Weight Capacity	50 Kg
Suitable for Screens	32" to 42"*
To Top of Screen Plate	1820 mm
Keyed Locks Included	
Code	8FSLU 343i
* Dimensions of LCD and plasma panels can vary. To ensure correct mounting plate is supplied, please advise panel size (diagonal) when ordering.	



Optional Shelf



Manufactured & Distributed By:



PO Box 63  
 Moorebank NSW 1875  
 337 - 349 Newbridge Road  
 Moorebank NSW 2170

Tel: (02) 9914 0900  
 Fax: (02) 9914 0901  
 Email: sales@gilkon.com.au

[www.gilkonaxis.com.au](http://www.gilkonaxis.com.au)

Plasma/LCD Stands  
Commercial Series  
Mobile Display Floor Stand – Economy



SPEC SHEET

8FSLU 343i

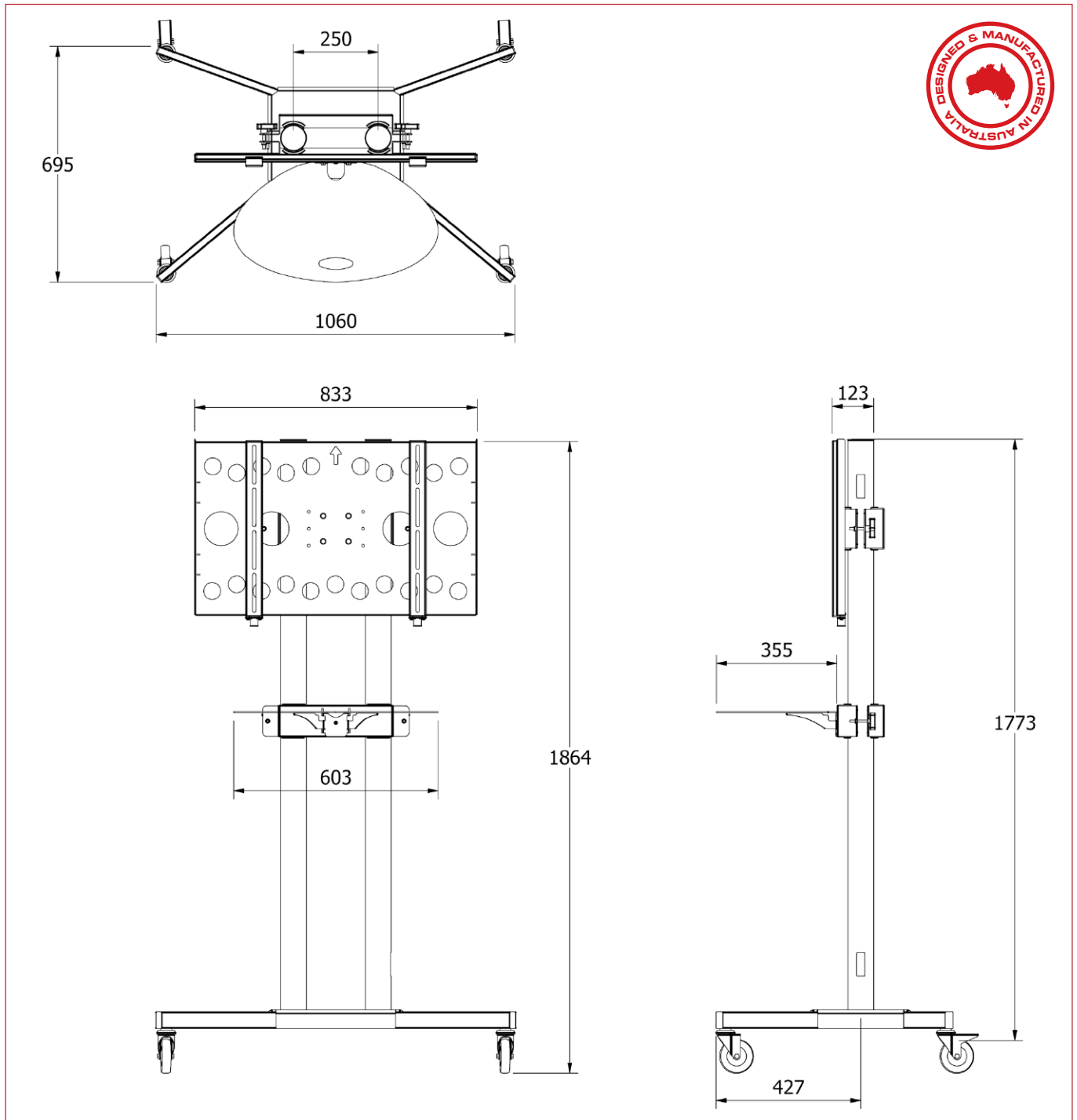

Manufactured & Distributed By:



PO Box 63  
Moorebank NSW 1875  
337 - 349 Newbridge Road  
Moorebank NSW 2170

Tel: (02) 9914 0900  
Fax: (02) 9914 0901  
Email: sales@gilkon.com.au

[www.gilkonaxis.com.au](http://www.gilkonaxis.com.au)