

# Plasma/LCD Stands

## Commercial Series

### Plasma Display Floor Stand



SPEC SHEET

#### Features

Boardrooms, entrance lobbies, retail displays and many other facilities can be complimented with a plasma display mounted on the Gilkon 8FSLU 339 Floor Stand. This unit will accommodate virtually any size display up to 100 kg.

Column has cable management. Includes bracket for plasma screen. Bracket can be secured with keyed push button locks to prevent theft. Silver pearl finish. Two accessory shelves to hold VCR, DVD and related equipment are included.

**Made by Gilkon in Australia.**

PLASMA DISPLAY FLOOR STANDS	
Weight Capacity	80 Kg
Suitable for Screens	32" to 50"*
Top of Column to Base	1831 mm
Keyed Locks Included	
Code	8FSLU339B
* Dimensions of LCD and plasma panels can vary. To ensure correct mounting plate is supplied, please advise panel size (diagonal) when ordering.	



Screen not included



Manufactured & Distributed By:



PO Box 63  
Moorebank NSW 1875  
337 - 349 Newbridge Road  
Moorebank NSW 2170

Tel: (02) 9914 0900  
Fax: (02) 9914 0901  
Email: sales@gilkon.com.au

[www.gilkonaxis.com.au](http://www.gilkonaxis.com.au)

Plasma/LCD Stands  
Commercial Series  
Plasma Display Floor Stand



SPEC SHEET

8FSLU339B

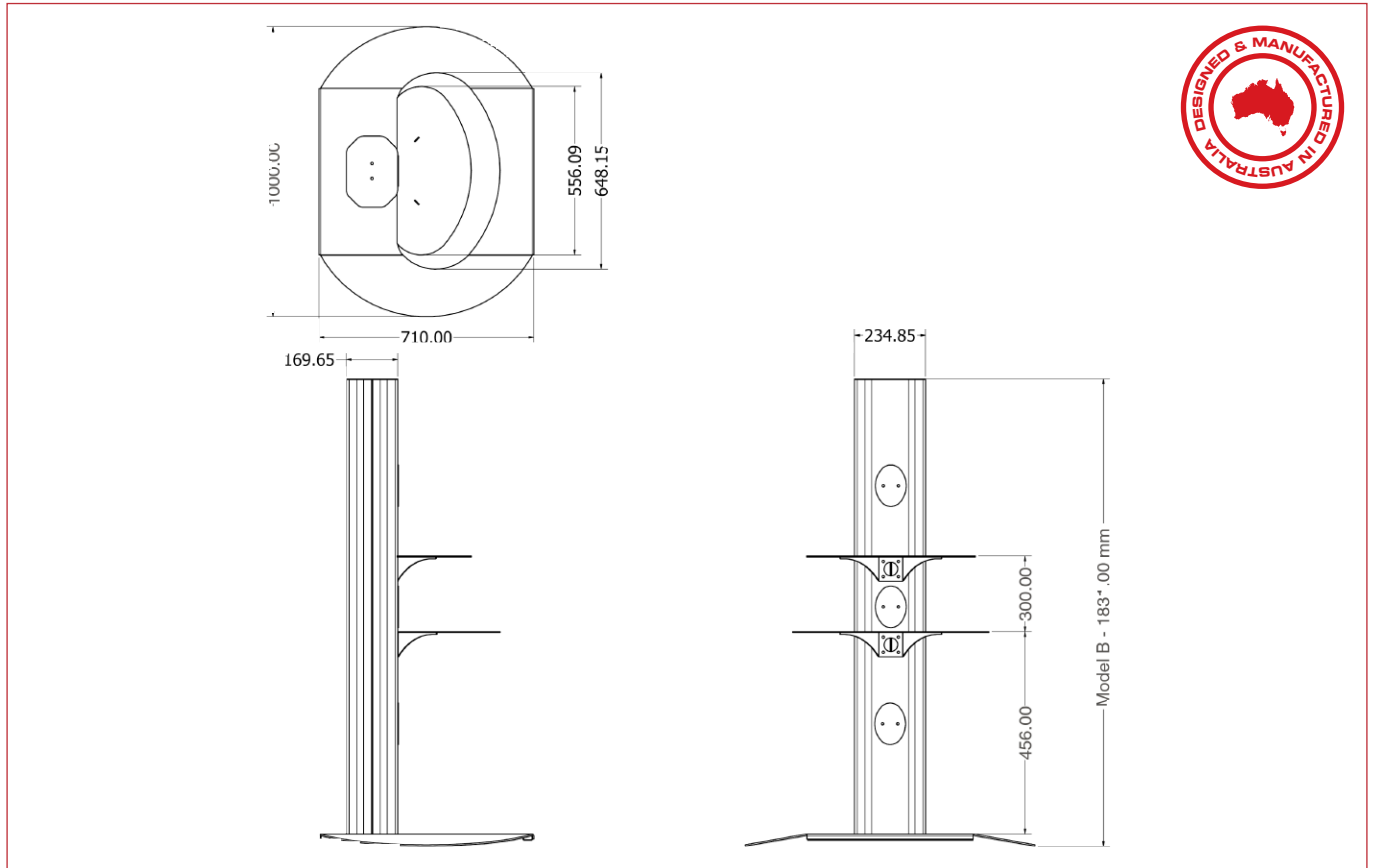

Manufactured & Distributed By:



PO Box 63  
Moorebank NSW 1875  
337 - 349 Newbridge Road  
Moorebank NSW 2170

Tel: (02) 9914 0900  
Fax: (02) 9914 0901  
Email: sales@gilkon.com.au

[www.gilkonaxis.com.au](http://www.gilkonaxis.com.au)